

Pressure Module (PM)

ACCURACY

MPa (Gauge Pressure)

300 kPa, 1 MPa, and 3 MPa modules

0 to 30% of Range: $\pm(0.0075\%$ of Full Scale)

30 to 110% of Range: $\pm(0.025\%$ of Reading)

Vacuum: $\pm(0.06\%$ of Full Scale*, typical)

* Full Scale = -99.9 kPa

10 and 30 MPa modules

0 to 30% of Range: $\pm(0.015\%$ of Full Scale)

30 to 110% of Range: $\pm(0.05\%$ of Reading)

70 and 100 MPa modules

0 to 30% of Range: $\pm(0.03\%$ of Full Scale)

30 to 110% of Range: $\pm(0.1\%$ of Reading)

Includes all effects of linearity, hysteresis, repeatability, temperature, and stability for one year.

All models indicate vacuum, but vacuum specification (typical) applies to 300 kPa, 1 MPa, and 3 MPa models only.

Not recommended for continuous use at high vacuum.

Refer to [XP2i-DP data sheet](#) for gauges that are intended for continuous high vacuum use.

MPaA (Pressure with BARO module)

300 kPa module

1.38 to 100.00 kPaA: ± 0.08 kPaA, typical

100.00 to 400.00 kPaA: $\pm(0.025\%$ of Reading)+0.03 kPaA

1 MPa module

0.00138 to 0.10000 MPaA: ± 0.00008 MPaA, typical

0.10000 to 0.40000 MPaA: ± 0.00010 MPaA

0.40000 to 1.10000 MPaA: $\pm(0.025\%$ of Reading)

3 MPa module

0.0014 to 0.1000 MPaA: ± 0.0001 MPaA, typical

0.1000 to 1.000 MPaA: ± 0.0003 MPaA

1.000 to 3.1000 MPaA: $\pm(0.025\%$ of Reading)

10 MPa module

0.1000 to 3.1000 MPaA: ± 0.0015 MPaA

3.1000 to 10.1000 MPaA: $\pm(0.05\%$ of Reading)

30 MPa module

0.100 to 9.100 MPaA: ± 0.005 MPaA

9.100 to 30.100 MPaA: $\pm(0.05\%$ of Reading)

70 MPa module

0.100 to 21.100 MPaA: ± 0.021 MPaA

21.100 to 70.100 MPaA: $\pm(0.1\%$ of Reading)

100 MPa module

0.100 to 30.100 MPaA: ± 0.030 MPaA

30.100 to 100.100 MPaA: $\pm(0.1\%$ of Reading)

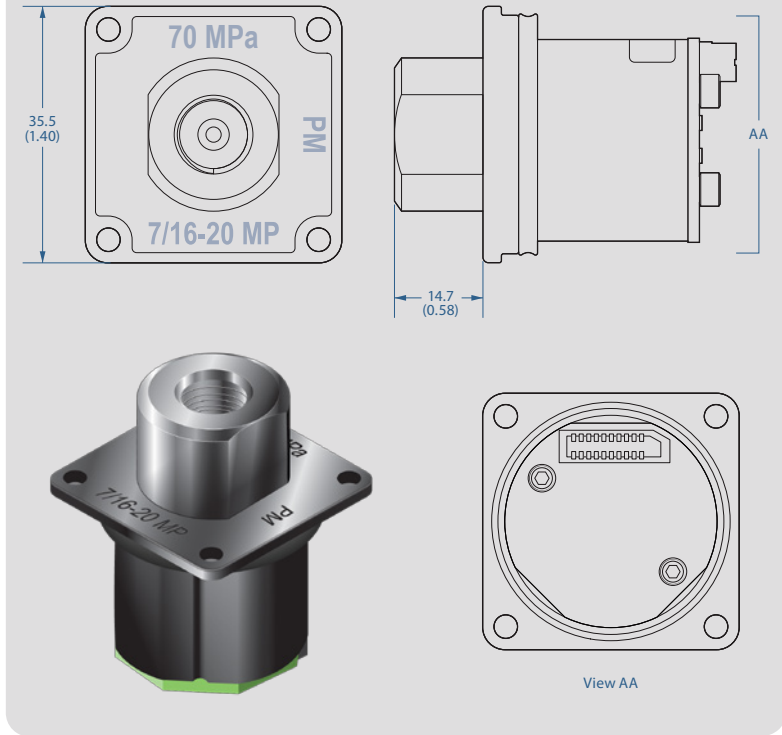

DIFFERENTIAL PRESSURE MEASUREMENT UNCERTAINTIES WITH TARE

The Tare function can improve measurement uncertainties on two modules with the same full scale pressure range installed into one nVision Reference Recorder. Requires the use of an equalizing valve.

The following specifications apply to the measurement system with a logging interval of 1 second/reading:

Full Scale Range of Both Sensors MPa	The Greater of (+/-)				or	% of DP Reading
	mbar	PSI	inH ₂ O	mmH ₂ O		
300 (kPa)	0.04	0.0005	0.014	0.4	or	0.025%
1	0.10	0.0015	0.04	1.0	or	0.025%
3	0.4	0.005	0.14	4.0	or	0.025%
10	1.0	0.02	0.4	10.0	or	0.05%
30	4.0	0.05	1.4	n/a	or	0.05%
70	10.0	0.2	4.0	n/a	or	0.1%
100	15.0	0.3	6.0	n/a	or	0.1%

Unit must be enabled in CrystalControl

DIFFERENTIAL PRESSURE MEASUREMENT UNCERTAINTIES WITHOUT TARE

The total nVision Reference Calibrator measurement uncertainty in the ΔP mode configuration will need to consider the uncertainties of both pressure modules. We recommend the module uncertainties to be combined with the preferred square root of the sum of the squares (or “root sum squares”) method.

The following table lists the possible combinations of using Pressure Modules (PM) with different accuracy statements. The uncertainties reported below are without the use of the Tare feature, which will greatly improve your measurement uncertainty.

		Upper Pressure Module Uncertainties (of Static Line Pressure) (of Reading)		
		0.025%	0.05%	0.10%
Lower Pressure Module Uncertainties (of Static Line Pressure) (of Reading)	0.025%	0.035%	0.056%	0.103%
	0.05%	0.056%	0.071%	0.112%
	0.10%	0.103%	0.112%	0.141%

SENSOR

Wetted Materials: (WRENCH TIGHT) **316 stainless steel**

(FINGER TIGHT) **316 stainless steel
and Viton® (internal o-ring)**

Diaphragm Seal Fluid: **Dow Corning® 200**

Connection: **Crystal CPF Female**

All welded, with a permanently filled diaphragm seal.

Metal to metal cone seal; O-ring can be removed if necessary.

1/4" medium pressure tube system compatible with HIP LM4 and LF4 Series, Autoclave Engr SF250CX Male and Female Series.

CPF Adapters to NPT, BSP, and M20 available.

BAROMETRIC REFERENCE (BARO)

Accuracy: **± 0.5 mbar, ± 0.00725 PSI**

Range: **700.0 to 1100.0 mbarA,
10.153 to 15.954 PSIA**

Units and Resolution: **mbar 0.1
PSI 0.001
inHg 0.001
mmHg 0.01**

Pressure Connection: **Cylindrical sensor fitting of 5.8mm
OD. A flexible 4.8 mm [3/16"] ID
tube is recommended to connect for
for calibration.**

Mounting: **Secured using a 3/8" 4-40 plastic screw.**

*Includes all effects of linearity, hysteresis, repeatability,
temperature, and stability for one year.*

*Exposure to environmental extremes of temperature, shock, and/
or vibration may warrant a more frequent recertification period.*

Other units available depending on the installed modules.



Current, Voltage, & Switch Test Module (MA20)

Intended for use with a 4-20mA loop measurement. This module is also capable of measuring supply voltages and has an auxiliary fixed output for use in switch open/closure testing. Each MA20 module includes a super flexible silicone test lead kit (P/N 3952).

CURRENT & VOLTAGE MEASUREMENT

Current (mA) Input

Accuracy: $\pm(0.015\% \text{ of rdg} + 0.002 \text{ mA})$

Range: **0 to 55 mA (MA20+)**
0 to 25 mA (MA20)

Max Allowable Current: **93.3 mA**

Resolution: **0.001 mA or 0.01%**

Units: **mA, % 4-20, % 10-50**

Input Resistance: **< 17.2 Ω**

Voltage Burden @ 20mA: **< 0.35 V**

Voltage Burden @ 50mA: **< 0.86 V**

HART Resistance: **250 Ω**

Connection: **2mm jacks**

Includes all effects of linearity, hysteresis, repeatability, temperature, and stability for one year.

WARNING: ATEX and IECEx certification does not allow the installation of two MA20 modules.

Inputs protected by a resettable fuse.

mA can be displayed as a percentage, where 0 to 100% corresponds to either 4 to 20 mA or 10 to 50 mA.

Jacks are compatible with safety sheathed banana plugs.

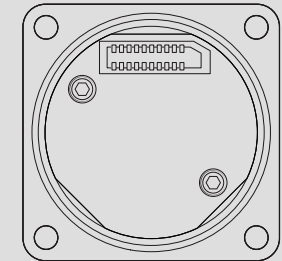
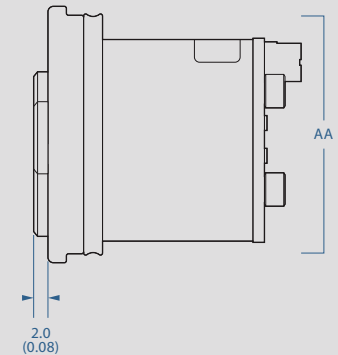
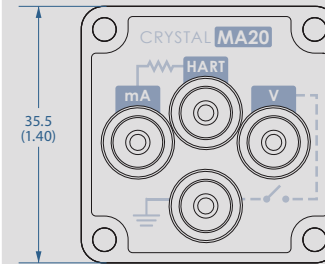

View AA

Voltage (VDC) Input

Accuracy: $\pm(0.015\% \text{ of rdg} + 0.002 \text{ VDC})$

Range: **0 to 28 VDC**

Max Allowable Voltage: **30 VDC**

Resolution: **0.001 VDC**

Units: **VDC**

Includes all effects of linearity, hysteresis, repeatability, temperature, and stability for one year.

Switch Test

Switch Type: **Dry Contact**

Closed State Resistance: **< 10 Ω**

Open State Resistance: **> 10 M Ω**

Switch state change indicated by bright green LED flash.

Switch test screen reports switch open, close, and deadband values.



ATEX and IECEx Scheme Entity Parameters

The MA20 Module has these specific input entity parameters:

Ui = 28 V	Uo = 6.6 V
Ii = 93.3 mA	Io = 4.45 mA
Pi = 653.3 mW	Po = 7.34 mW
Ci = 0.36 μF	Co = 0.5 μF*
Li = 39.1 μH	Lo = 12 μH**

* Dependent on the supply to the terminals but shall not be greater than 0.5 μ F

** Total cable inductance between all modules

Temperature Module (RTD100)

Calibrated for Pt100 RTD/PRT (100 Ohms at 0°C Platinum Resistance Temperature Detector) sensors conforming to DIN/IEC 60751 (or IEC751) with US, Euro, or Lab calibration curves. An RTD is not included, but each RTD100 includes P/N 3953 RTD Connection Kit.

TEMPERATURE MEASUREMENT

Resistance Input

Accuracy: $\pm (0.015\% \text{ of rdg} + 0.02 \Omega)$

Range: **0 – 400 Ohms range for use with 100 Ohm PRTs**

Resolution: **0.01 on all scales**

Units: °C, K, °F, R, Ω

TCRs: **0.003850 $\Omega/\Omega/^\circ\text{C}$ (IEC 60751), 0.003911 $\Omega/\Omega/^\circ\text{C}$ (US Industrial Std), 0.003926 $\Omega/\Omega/^\circ\text{C}$**

Wiring: **2-, 3-, 4-wire support**

Connection: **M8 connector cable or terminal block**

Includes all effects of linearity, hysteresis, repeatability, temperature, and stability for one year.

The proper selection of the RTD sensing element is very important as the error associated with this device is the majority of the overall system measurement uncertainty. IEC 751 is the standard that defines the temperature versus resistance for 100 Ω , 0.00385 $\Omega/\Omega/^\circ\text{C}$ platinum RTDs. IEC 751 defines two classes of RTDs: Class A and B. Class A RTDs operate over the -200 to 630 $^\circ\text{C}$ range versus -200 to 800 $^\circ\text{C}$ for the Class B elements. For example, the Class A uncertainty is about half that of the Class B elements as illustrated in the following table.

Temperature	nVision Uncertainty		Class A				Class B			
			Class A Uncertainty		nVision + Class A Uncertainty		Class B Uncertainty		nVision + Class B Uncertainty	
°C	$\pm\Omega$	$\pm^\circ\text{C}$	$\pm\Omega$	$\pm^\circ\text{C}$	$\pm\Omega$	$\pm^\circ\text{C}$	$\pm\Omega$	$\pm^\circ\text{C}$	$\pm\Omega$	$\pm^\circ\text{C}$
-200	0.02	0.05	0.24	0.55	0.24	0.55	0.56	1.30	0.56	1.30
0	0.04	0.09	0.06	0.15	0.07	0.17	0.12	0.30	0.12	0.31
200	0.05	0.13	0.2	0.55	0.21	0.56	0.48	1.30	0.48	1.31
400	0.06	0.17	0.33	0.95	0.33	0.96	0.79	2.30	0.79	2.31
600	0.07	0.21	0.43	1.35	0.44	1.37	1.06	3.30	1.06	3.31
800	0.08	0.25	0.52	1.75	0.53	1.77	1.28	4.30	1.28	4.31

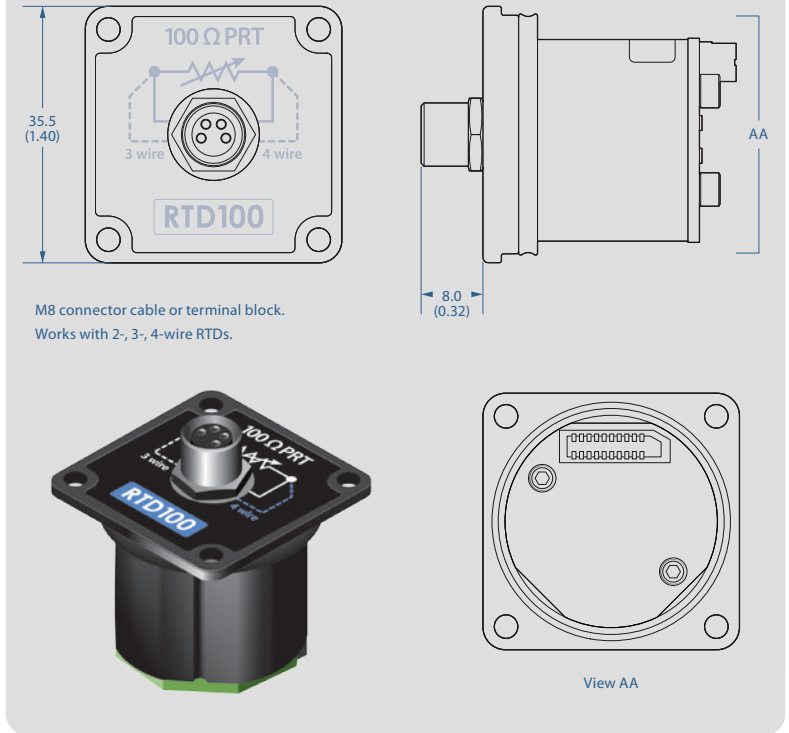

M8 connector cable or terminal block. Works with 2-, 3-, 4-wire RTDs.

View AA

ATEX IECEx ATEX and IECEx Scheme Entity Parameters

The RTD100 Module has these specific input entity parameters:

- U_i = 0 V**
- U_o = 9.73 V**
- I_i = 0 A**
- I_o = 1.6642 A**
- P_i = 0 W**
- P_o = 1.1 W**
- C_o = 0.5 μF**
- L_o = 12 μH^***

* Total cable inductance between all modules

nVision Chassis (NV)

OPERATING TEMPERATURE

Temperature Range: **-20 to 50° C (-4 to 122° F)**

< 95% RH, non-condensing. No change in accuracy over operating temperature range. Gauge must be zeroed to achieve rated specification.

Applies to all modules.

DISPLAY

Screen: **255 x 160 pixel graphical display**

LCD readable in sunlight with bright backlight.

Display Rate: **4 readings/second (standard)
up to 10 readings/second (recording)**

POWER

4 x AA: **200 hours, typical**

Ultra Low Power: **Up to 60 days, typical***

Approved Batteries: **The nVision is Intrinsically Safe only if powered by one of the following battery types:**

*2 installed modules, 1 reading per 5 minute recording interval, and 23°C ambient temperature.

WARNING: Do not use the mini-USB serial interface in hazardous locations.

WARNING: Replace batteries with approved type in non-hazardous locations only.

Uses 4 alkaline AA (LR6) batteries. Use of backlight reduces operating time.

**Energizer is manufactured by Energizer Holdings, Inc., and the Eveready Battery Company, Inc.

Approved Battery Type	Ta=	Marking
Rayovac Max Plus 815	-20 to 50° C	Ex ia IIB T4 Ga
Duracell MN1500	-20 to 45° C	
**Energizer E91, EN91	-20 to 50° C	Ex ia IIB T3 Ga
Duracell MN1500		

DATA/COMMUNICATION

Digital Interface: **mini-USB**

The mini USB will power the nVision with or without the battery pack installed.

WARNING: Do not use the mini-USB serial interface in hazardous locations.

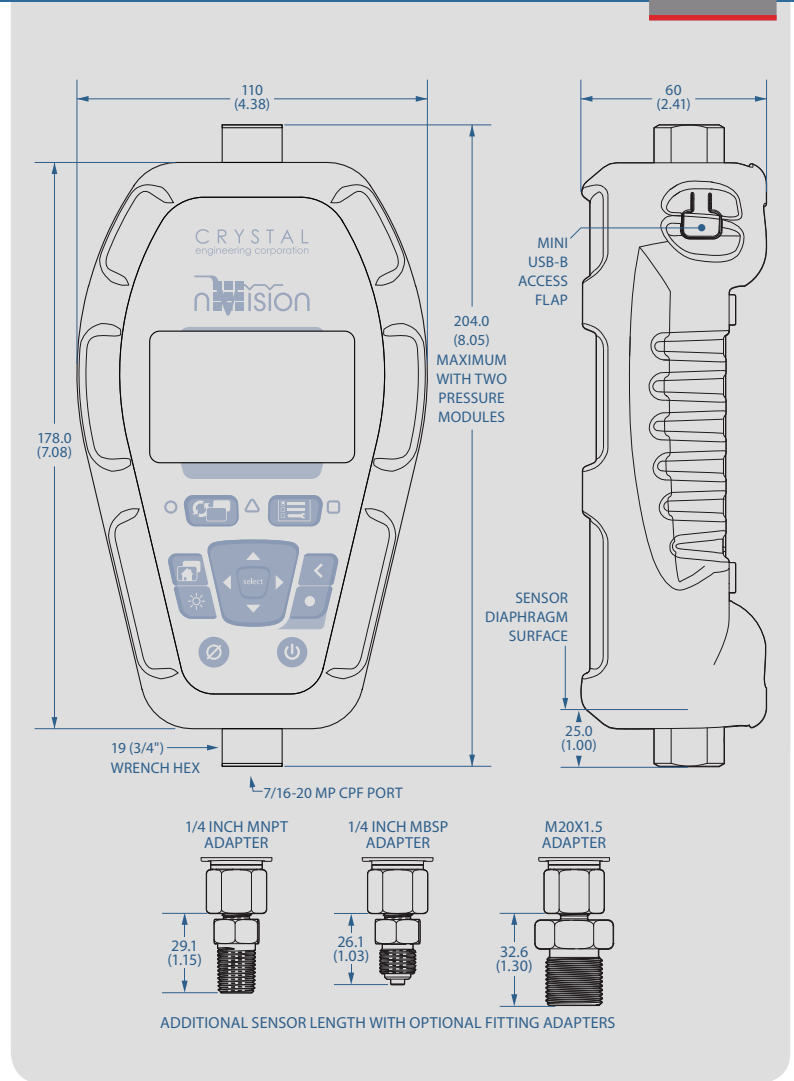

DATALOGGING

Capacity: **Approx. 1,000,000 data points***

Storage Type: **Non-volatile flash memory**

Fastest Interval: **10 per second**

Slowest Interval: **1 per hour**

**Single Module Recording*

The included CrystalControl software is compatible with 32 & 64 bit Windows 7 and Vista, and XP (32 bit only). Produces csv, xls, pdf, or signed pdf files, and uses Excel template files (samples included) to automatically format and graph data.

ENCLOSURE

Weight: **680 g (24.0 oz)**

Rating: **IP67**

Housing: **Impact resistant injection molded**

Keypad and Labels: **UV Resistant Polyester**

Mounting: **M4 x 0.7 [8 mm (0.31")]** deep threaded insert mounting locations

Weight includes one pressure module, one RTD module, 4AA battery module, and protective boot.

Submersible to 1 m for 30 minutes [IEC 60529].

LCD protected from impact damage by 1.5 mm (0.06") thick polycarbonate lens.

Skydrol® compatible.

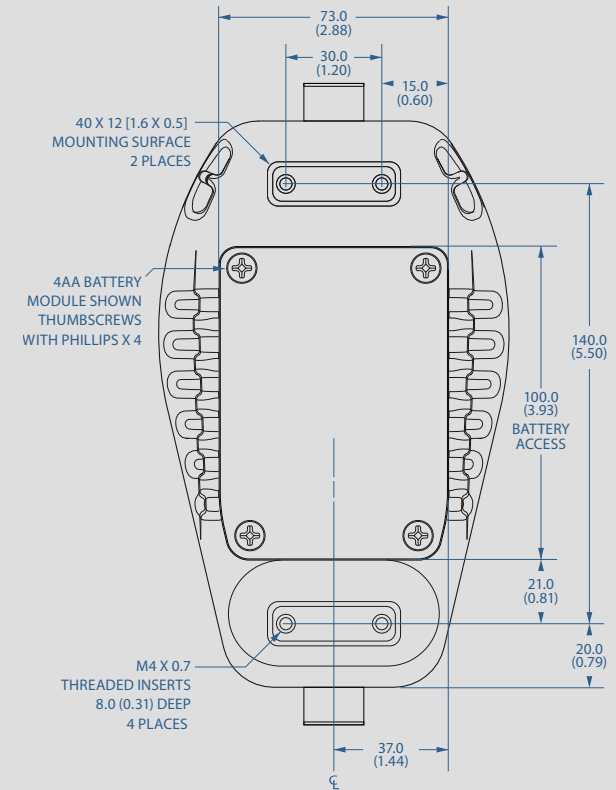

STORAGE TEMPERATURE

Temperature Range: **-40 to 75° C (-40 to 167° F)**

Batteries should be removed if stored for more than one month.

SPECIAL FEATURES

The following requires the use of our free [CrystalControl](#) software

Averaging Screen: **Averages all points in a recording run.**

Data Point Counter: **Screen for counting the data points logged.**

Display Screens: **Turn on and rearrange display screens.**

Estimated Recording Time: **A CrystalControl calculation based on active screens and logging interval.**

Live PC Graph: **During a recording, graph directly to your PC.**

Password Protect: **Changes to configuration or userspan calibration factor(s).**

Pressure Switch Test: **Using a PM and MA20, get deadband and state-change pressure.**

Remove: **Unwanted pressure units.**

Run Tags: **Create and enable run tags that will identify logging runs.**

Screen Numbers: **Number each display screen to make writing procedures around the nVision easier.**

Secure Documents: **Download into secure pdf documents for tamper proof records.**

Start-up Screen: **Define a 32-character prompt which requires user acknowledgement at startup.**

User Defined Unit: **Define and display any pressure units not included, or to use the gauge to display force, level or other pressure related parameters.**

CERTIFICATIONS



II 1G Ex ia IIB T4 Ga or T3
SIRA 09ATEX2008X

This product conforms to:

EN 60079-0: 2006 | EN 60079-11: 2007 | EN 60079-26: 2007



Ex ia IIB T4 Ga or T3
IECEx SIR09.0053X

This product conforms to:

IEC 60079-0: 2004 | IEC 60079-11: 2006 | IEC 60079-26: 2006



nVision complies with the Electromagnetic Compatibility and the Pressure Equipment Directives. Refer to the EC Declaration of Conformity for specific details.



The instrument was tested against **AS/NZS 3584**, C-tick EMC/EMI requirements.



XP2i is approved for use as a portable test instrument for Marine use and complies with Det Norsjke Veritas' Rules for Classification of Ships, High Speed & Light Craft and Offshore Standards.

RANGE & RESOLUTION TABLE

PM	Range (MPa)	Over-pressure	Display Resolution			
			MPa	kPa	bar	mbar
300KPA	300(kPa)	3.0 x		0.01	0.0001	0.1
1MPa	1	2.0 x	0.00001	0.01	0.0001	0.1
3MPa	3	2.0 x	0.0001	0.1	0.001	1
10MPa	10	2.0 x	0.0001	0.1	0.001	
30MPa	30	1.5 x	0.001	1	0.01	
70MPa	70	1.5 x	0.001	1	0.01	
100MPa	100	1.3 x	0.001	1	0.01	

Add one digit of resolution for differential mode.

ORDERING INFORMATION

Product ID	Power	Module: Upper	Module: Lower	BARO Module?
NV	4AA	_____	_____	_____
		PM	PM	No: (omit)
		MA20	MA20	Yes: -BARO
		RTD100	RTD100	
		BNKPLT	BNKPLT	

If ordering a nVision with only one module installed, please enter "BNKPLT" in the empty module slot.

SAMPLE PART NUMBERS

NV-4AA-300KPA-30MPa-BARO nVision with 300 kPa pressure module (upper) and 30 MPa pressure module (lower) with BARO module option

NV-4AA-RTD100-70MPa nVision with RTD100 temperature module (upper) and 70 MPa pressure module (lower)

* MPA versions available in USA direct from factory, only.

ACCESSORIES (Included with NV)

Soft Carrying Case P/N 4087

Durable, padded case with separate pockets for your nVision and accessories.

Protective Boot P/N 3985

Shock resistant protection, low durometer, Skydrol resistant.

Mini-USB Cable P/N 3951

Connect to your nVision with 6' [1.8m] cable.

COMPLIMENTARY PRODUCTS

Crystal Engineering offers a wide range of products that work with the nVision:

- [Fittings that connect without tools, safely and without leaks](#)
- [Lightweight, super flexible high pressure hoses](#)
- [Fitting kits and adapters](#)
- [Pneumatic hand pumps](#)
- [Hydraulic hand pumps](#)
- [Portable pressure comparators](#)
- [Software, for the quickest way to calibrate pressure transmitters and gauges](#)

Dow Corning is a registered trademark of Dow Corning Corporation.